



**VALVE REGULATED  
LEAD ACID BATTERY (V.R.L.A.)**

**ABSORBED GLASS MAT  
TECHNOLOGY (A.G.M.)**

**10 YEAR DESIGN FOR UPS AND  
STANDBY APPLICATIONS**

### Features

- Gas recombination greater than 99%.
- Operates at a low internal pressure.
- Never needs watering, minimal maintenance.
- 99.7% pure lead calcium grids.
- Shock absorbent thick wall construction.
- Cold forged non-porous terminal bushings, eliminate post leakage.
- Thermally welded case to cover bond, eliminates both acid and electrical leaks.
- Over-sized, through the partition inter-cell welds provide low resistance connections, with minimal power loss.
- Each cell has a low pressure safety release venting system, recognized per U.L. 924.
- Measured high vacuum acid fill, reduces electrical variability between cells.
- 100% recyclable materials.

### Options

- The TC-1290S battery has a flame retardant polypropylene case and cover compliant with UL 1778; with an oxygen index greater than 28%.
- Terminal covers and custom inter-connecting battery cables.

### Specifications

Cells per unit	6
Nominal voltage	12
Terminal type	1/4" stud
Maximum discharge current	500 amps
Short circuit current	3209 amps
Impedance @ 77°F 25°C	4.30 milliohms
Weight lbs / kgs	60.6 / 27.5
Electrolyte (S.G.)	1.300
Capacity @ 77°F (25°C) to 1.75 V.P.C.	75.8 AH (20 hrs) 68.6 AH (8 hrs)
Ideal operating temperature range	+68°F (+20°C) to +77°F (+25°C)
Extended operating temperature range	Discharge: -40°F (-40°C) to +140°F (+60°C) Charge: -40°F (-40°C) to +122°F (+50°C)
Float Voltage	13.5 to 13.8 @ 77°F (25°C)
Maximum charging current	C/4 amperes at 100% discharge Unlimited at partial discharge.
AC ripple from charging source	1.5% peak to peak of float charge voltage
Storage	6 months at 77°F (25°C)

### No transport restrictions

- Surface transport. Classified as non-hazardous material as relates to DOT-CFR Title 49 part 171-189.
- Maritime transport. Non hazardous as per IMDG amendment 27.
- Air transport. Complies with IATA / ICAO, special provision A67.

### DISCHARGE SPECIFICATIONS

#### Constant power ratings, Watts per battery @ 77°F (25°C) in minutes

Final V.P.C.	5	10	15	20	30	40	45	50	60	90
1.60	3007	2230	1721	1408	1043	837	771	705	574	418
1.67	2904	2188	1701	1395	1036	831	766	702	571	417
1.70	2860	2172	1691	1387	1031	829	765	701	570	414
1.75	2711	2045	1630	1360	1022	822	758	694	565	413

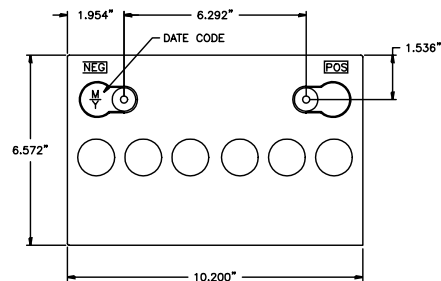
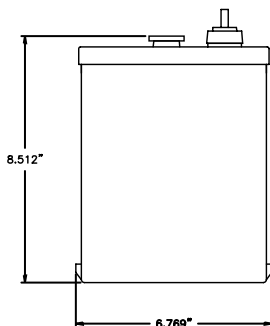
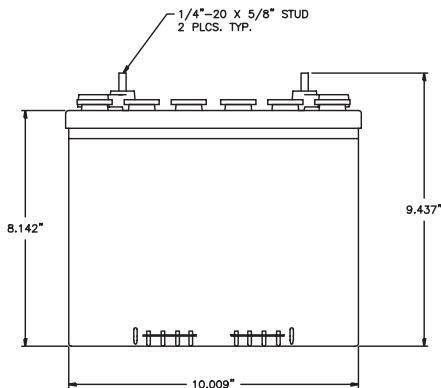

**CR3 cabinet model**

POWER BATTERY offers an extensive line of pre-wired and fused battery cabinets complete with UL and CUL approval. Standard and custom DC voltages complete with breakers and chargers are available.

Battery Cabinet Systems (pre-wired with PRC/TC-1290Ss)					
Battery cabinet model	Maximum # of batteries	Dimensions			
		inches / millimeters			Weight lbs / kgs
		W	D	H	
KS5	4	15.0 / 381	25.0 / 635	15.75 / 400	287 / 131
KS6	5	16.0 / 406	34.5 / 876	17.75 / 451	378 / 172
KS7	10	16.0 / 406	34.5 / 876	37.25 / 946	756 / 344
CR1	12	24.0 / 610	32.5 / 826	43.0 / 1092	987 / 449
CR3	20	40.0 / 1016	32.5 / 826	43.0 / 1092	1538 / 699
CR6	30	40.0 / 1016	32.5 / 826	60.0 / 1524	2260 / 1027
CR4	40	40.0 / 1016	32.5 / 826	77.0 / 1956	2982 / 1355

Constant current ratings, Amperes @ 77°F (25°C) in hours										
Final V.P.C.	1	2	3	4	5	6	8	10	12	24
1.75	47.6	27.7	20.1	15.8	13.0	11.1	8.58	7.00	5.98	3.22
1.80	46.9	27.5	19.9	15.5	12.8	10.9	8.48	6.96	5.92	3.18
1.85	45.1	26.6	19.2	15.0	12.4	10.6	8.20	6.73	5.72	3.07
1.90	41.5	24.9	18.1	14.2	11.7	9.90	7.66	6.21	5.23	2.84

1219-2-0205

**U.S.A.**  
**Power Battery Company, Inc.**  
 25 McLean Blvd.  
 Paterson, N.J. 07514-1507  
 Phone: (973) 523-8630  
 Fax: (973) 523-3023  
 E-mail: sales@powbat.com  
 Website www.powerbattery.com

**CANADA**  
**Power Battery (Iberville) Ltd.**  
 770 Thomas Ave.  
 Iberville, Québec, J2X 5E7  
 Phone: (450) 346-3273  
 Fax: (450) 346-8003  
 E-mail: powerbat@sympatico.ca  
 Website: www.powerbattery.com

**UK**  
**Power Batteries Ltd.**  
 Premier Way, Abbey Park Industrial Estate  
 Romsey, Hampshire, SO51 9AQ  
 Phone: +44 (0)1794 835900  
 Fax: +44 (0)1794 835910  
 E-mail: sales@powbat.co.uk  
 Website: www.powbat.co.uk

**ITALY**  
**Power Battery Srl**  
 Via Locatelli 105  
 20046 Biassono MI - ITALY  
 Phone: +(39) 039 2324571  
 Fax: +(39) 039 2499200  
 E-mail: calberti@powbat.it  
 Website: www.powbat.it

**CHINA**  
**Power Battery (PACIFIC RIM) Ltd.**  
 Unit 1, 23/floor, Wealthy Plaza  
 138 Sau Kei Wan Road  
 Sai Wan Ho, Hong Kong  
 Phone: ++(852) 2-560-2222  
 Fax: ++(852) 2-967-8157  
 E-mail: bplhk@netvigator.com  
 Website: www.powerbattery.com